

Meter Test Equipment



Company Portrait

About us

MTE Meter Test Equipment AG is an internationally active family business (SME) based in Zug (Switzerland) with focus on measurement technology and the manufacturing of monitoring systems for power transformers. MTE is an innovative company focusing on accuracy and quality while offering a wide range of high-precision products worldwide for customers such as power

utilities, meter test laboratories, industrial companies as well as meter and transformer manufacturers. The support and distribution of this product range is guaranteed and continuously developed by a long-standing and first-class team of hardware and software engineers and a dynamic sales and service team.



While celebrating its 25th anniversary, MTE launched its next product generation “genX” for setting new standards in portable testing. The PWS 3.3 genX is MTE's latest three-phase electronic meter test unit for performing comprehensive and state-of-the-art on-site tests. Also in the field of transformer monitoring, MTE is driven by innovation and introduced the HYDROCAL 10xx genX series as new multi-gas online DGA devices.

Although MTE has a global strategy we act locally maintaining an experienced marketing, sales and service network of more than 100 carefully chosen exclusive distributor companies worldwide and subsidiaries in England, India and China. Whatever the needs, wherever the customers, MTE has the innovative solutions and the focus to contribute to the efficiency, profitability and quality of our customers.

Innovation has a name – MTE

Stationary meter test equipment

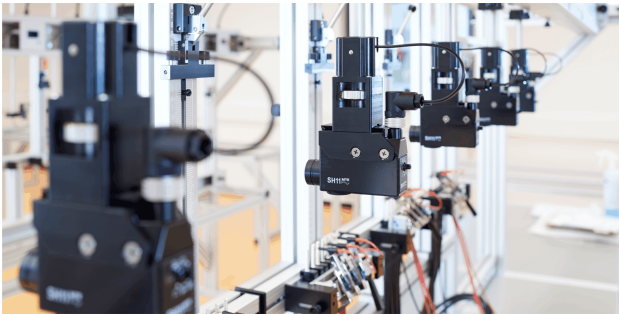

With its innovative, effective and customized test systems, MTE meets the challenges in the smart energy world and the changing requirements of the customers.

Meters measured and calibrated with high precision devices and systems protect utilities and customers against loss of revenue or over billing.

MTE's stationary test equipment covers all legal metrological test requirements for simple meters, high precision multifunction meters, smart meters and reference standards.

MTE knows the importance to upgrade existing test systems and thus provides solutions to gradually replace existing systems with modern components.

Portable meter test equipment

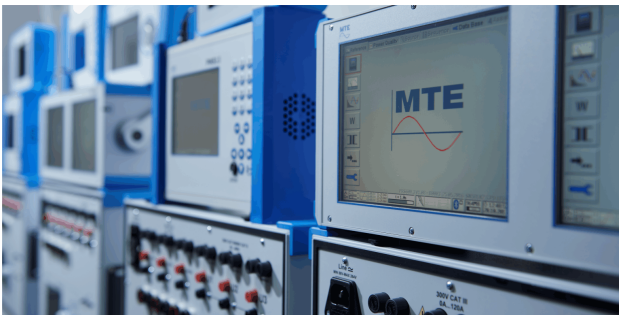

Single- and three-phase portable test devices from MTE are available over the complete range of accuracy classes for the use in on-site testing or in laboratories.

They are light in weight and its user friendly keyboard layouts and menu-driven software make the devices easy to operate.

MTE's portable test equipment is your reliable and solid partner for the on-site testing of different kind of meters:

- Accuracy checks of installed meters
- Identification of wiring and other system errors
- Periodic checks of meters used in industrial applications
- Handling customer's complaints

Transformer monitoring systems

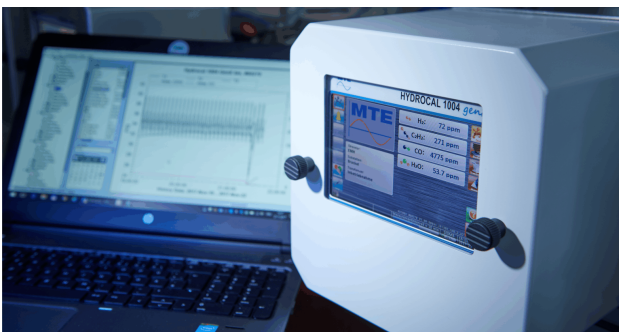

Analysis of the gases dissolved in power transformer oil is recognized as the most useful tool for early detection and diagnosis of incipient faults in transformers. The cost effectiveness of online dissolved gas analysis (DGA) and control systems have gained importance worldwide.

With its comprehensive product range for the online monitoring of transformers, MTE offers both the enhancing of the transformer lifetime and the contribution to a more secure high-voltage power transmission.

**MTE's products are manufactured in accordance with
DIN EN ISO 9001:2015**

Stationary meter test equipment

Universal meter test systems

MTE's universal meter test systems cover all state-of-the-art test requirements for modern single- and three-phase meters following IEC- and ANSI-standard. They perform fully automatic the meter calibration and verification procedures for meters with or without test link. Meter communication is integrated too, using different protocols. Thanks to the modular design, the number of measurement positions can be adapted specifically to the customer's needs.

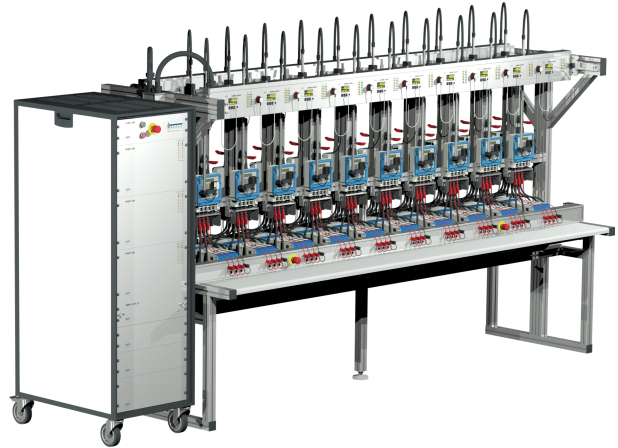

Example of meter test system with ICT 2.3 for the testing of 20 three-phase meters with closed links

Calibration of AC and DC electricity meters in the laboratory

MTE has a broad experience in the field of testing different electricity meters and hundreds of customized high precision meter test systems to its credit.

Based on its comprehensive product range and the modular system components MTE may cover all kind of standard requirements from the metering industry as well as upcoming adaptations in the course of EVSE and its components or specific AC and DC electricity meters.



Example of test bench for the calibration of 5 single-phase DC electricity meters

Solutions for meter manufacturers

For increasing the output volume (keyword "Smart Meter Rollout"), global meter manufacturers are asking for solutions to modernize their production processes and enhancing their efficiency.

MTE is a leading provider of sophisticated and highly customized Automatic Test Systems to reputable meter manufacturers around the world.

MTE's Automatic Test Systems are the answer for a sustainable increase in the output (testing) volume of single- or three-phase meters while improving customer's productivity.

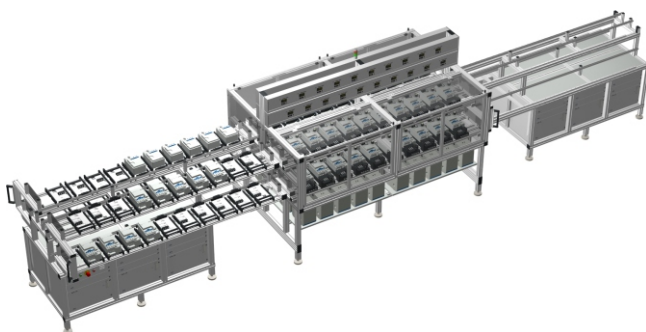

Example of an automatic three-phase test system for 40+40 positions

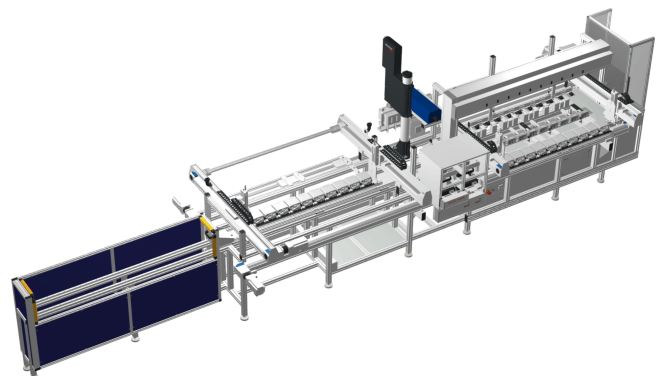

Example of a fully automatic smart test system for high volume testing of single-phase meters

Stationary meter test equipment

The individual system components of a MTE meter test system are modularly developed and can be combined in any order for testing of single- and three-phase meters with or without closed I-P links.

This modular design provides flexibility and enables MTE to offer the optimal customer orientated solutions.



Portable meter test equipment

Single- and three-phase portable test devices from MTE are available over the complete range of accuracy classes for the use in on-site testing or in laboratories.

They are light in weight and its user friendly operation layouts, design and menu-driven software make the devices easy to operate.

MTE follows the latest technologies and trends while carefully combining and embedding new features with well proved and tested operating principles and requirements in the field or laboratory.

MTE's portable test equipment is your reliable and solid partner for the on-site or lab testing of

different kind of meters and multiple applications:

- Revenue protection by periodic accuracy checks of installed meters and their installations
- Identification of wiring and other system errors
- Reduction of non-technical losses by detection of tampering, energy theft etc.
- Handling of customer's complaints

For such of relevant applications MTE offers a broad range of different devices which vary in their complexity and accuracy class. However they all follow and fulfill the following values and principals:



Portable meter test equipment

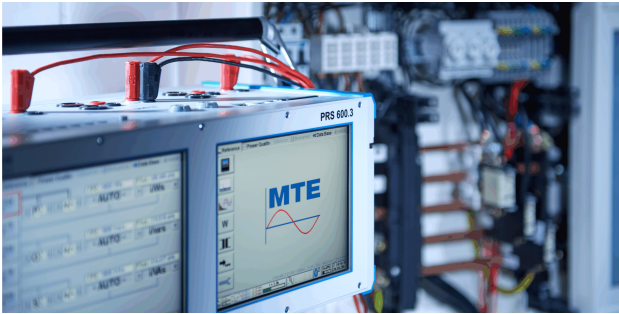

Portable reference standards

Comprehensive and innovative range of reference standards, single- or three-phase, available in class 0.2 up to 0.005. Ideal devices for the overall investigation for testing electricity meters and their installations on-site.

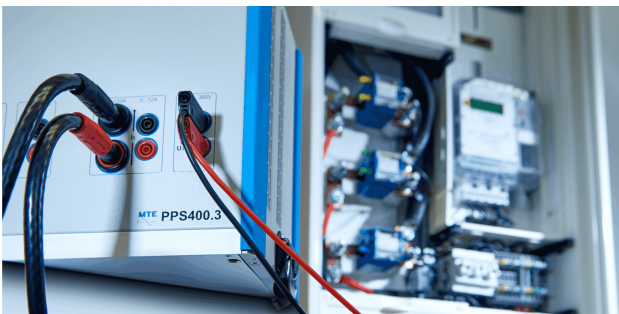

Portable power sources

Reliable and stable three-phase current or current and voltage sources allowing in-depth testing over the complete range.

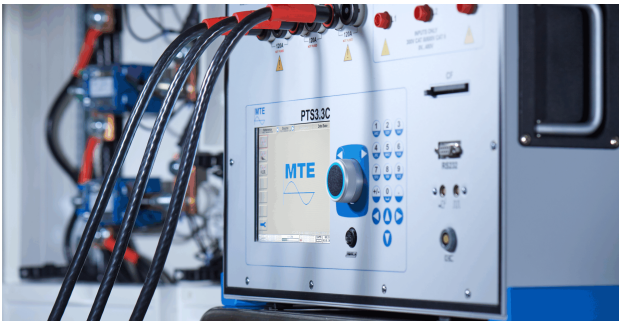

Portable test systems

Comprehensive portfolio of single- and three-phase meter test systems in class 0.2 up to 0.02 with current or current and voltage sources in different versions.

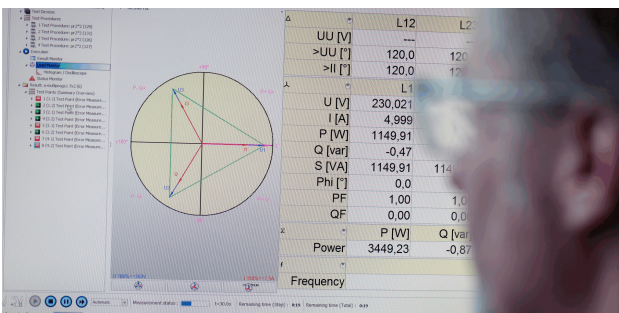

Software CAlegration®

CAlegration® is an all-in-one software package to operate MTE's portable and stationary test equipment product lines with the same software and on a common database. It bundles the functionalities and advantages in a new comprehensive software solution.

The philosophy of CAlegration® is to integrate all basic test elements (administration, database, operation, results) into one single software and to use it with both MTE's portable devices and stationary systems.

Portable meter test equipment

Portable meter test equipment from MTE can be used in all kind of laboratory and field applications. Thanks to its comprehensive product portfolio MTE provides their users with dedicated, innovativ devices for specific challenges. Over the last 25 years MTE has supplied thousands of portabels to different customers such as utilities, service companies, industries and meter manufacturers.



Challenges to be addressed with:

- Poor meter quality
- Damaged, inaccurate meters
- Tampering
- Energy theft

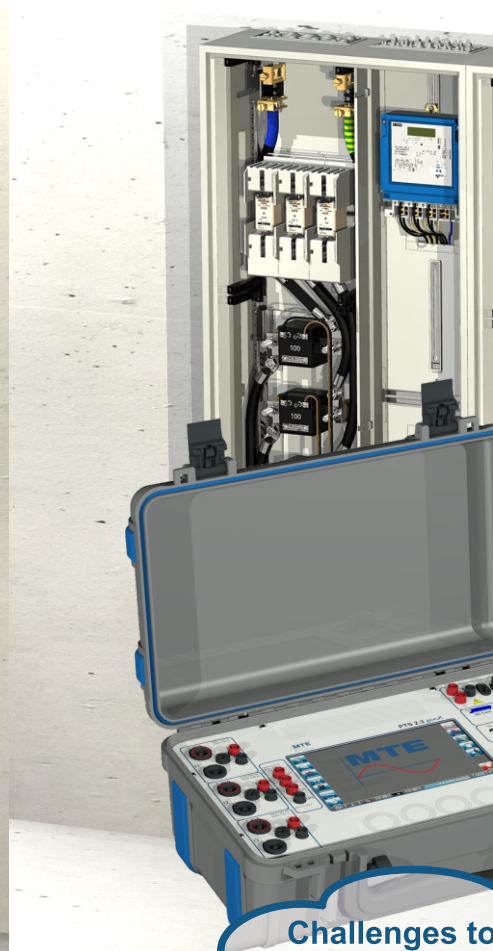

Challenges to

- Mistakes in m connection
- Changing CT
- Tampering
- Energy theft

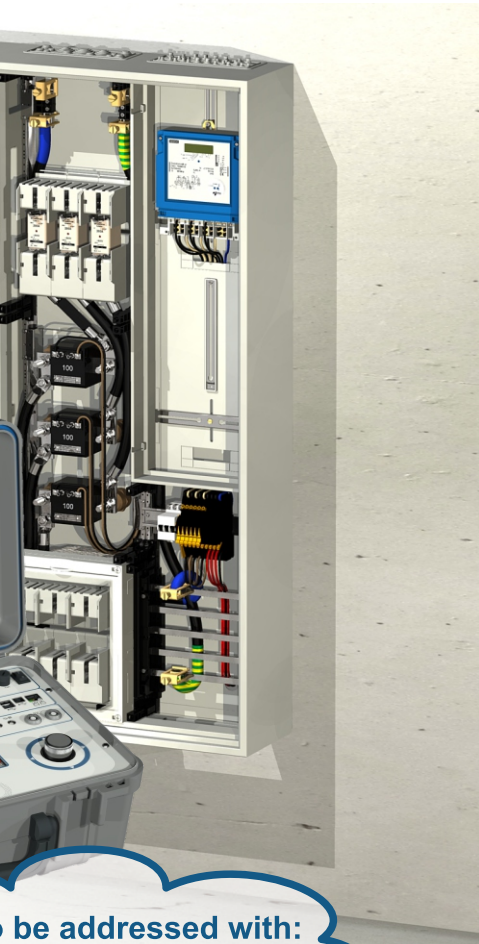

to be addressed with:
meter and CT/PT
ratio



Challenges to be addressed with:
■ Verification of accuracy and stability
■ Simulation of different values
■ Longtime testing

Advantages of MTE's solutions for Portable Test Equipment

- Comprehensive range of products for various applications and challenges
- Proven and compact design, light in weight
- Easy handling, user friendly operation layouts and menu-driven software
- Modern, innovative features and different communication connection possibilities
- Long-lasting experience and application know-how from thousands of supplies to hundreds of different customers worldwide

Transformer monitoring systems

Transformers are crucial for failure-free and stabilized operation of high-voltage power transmission. Transformer failures or disruptions can result in costly power outages or even in the total loss of expensive plant assets. Moreover transformers are the most cost intensive single component assets in high-voltage power transmission and should therefore be supervised with special care.

Analysis of the gases dissolved in power transformer oil is recognized as the most useful tool for early detection and diagnosis of incipient faults in transformers. The cost effectiveness of online dissolved gas analysis (DGA) and control systems are gaining importance worldwide.

With its comprehensive product range for the online monitoring of transformers, MTE offers both the extension of the transformer lifetime and the contribution to a more secure high-voltage power transmission.

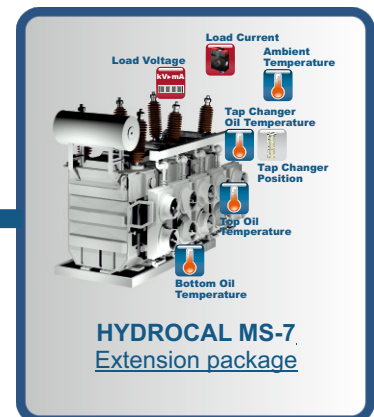
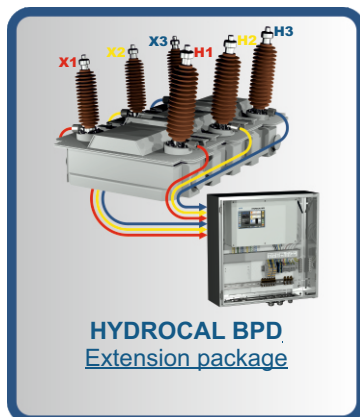
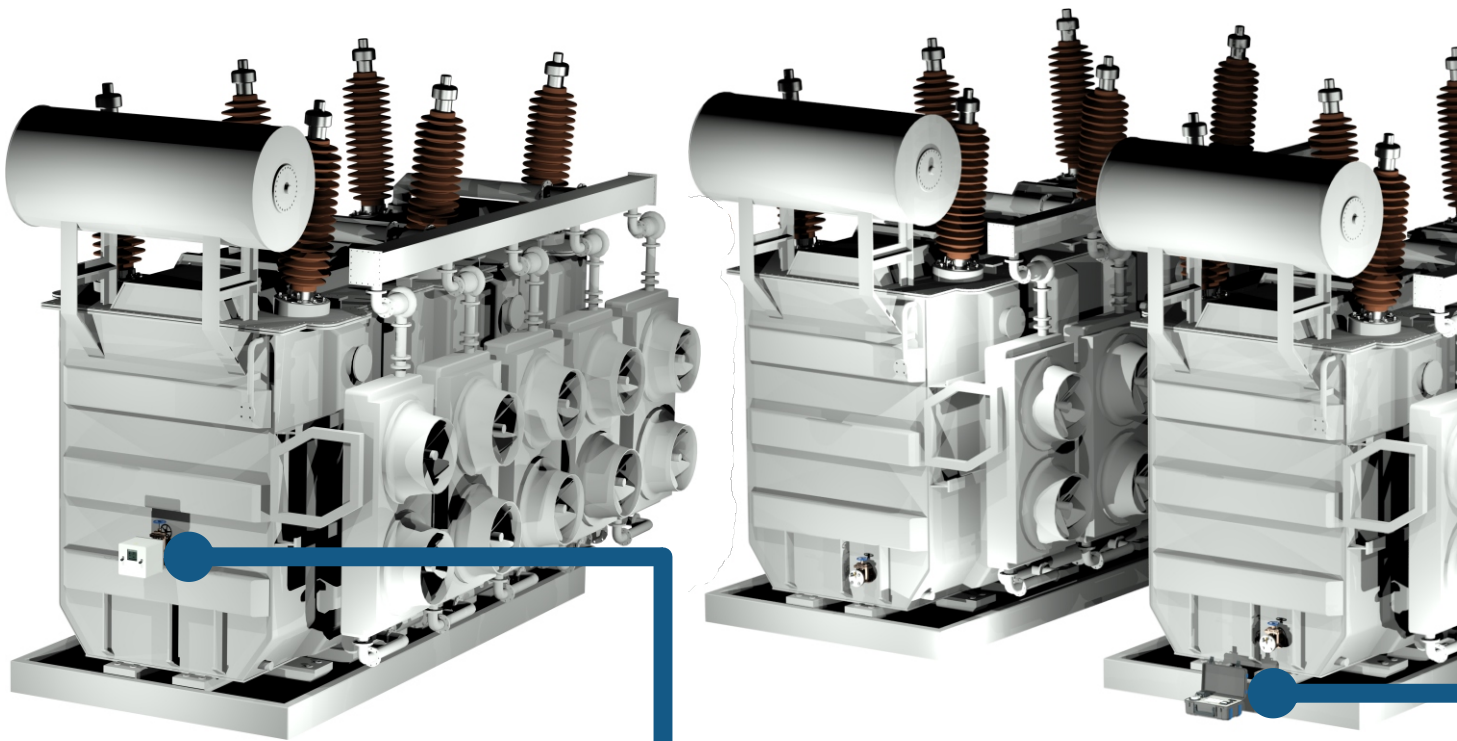



HYDROCAL 1011 genX P
Portable Dissolved
Gas Analysis



HYDROCAL genX
Truly maintenance-
free online DGA

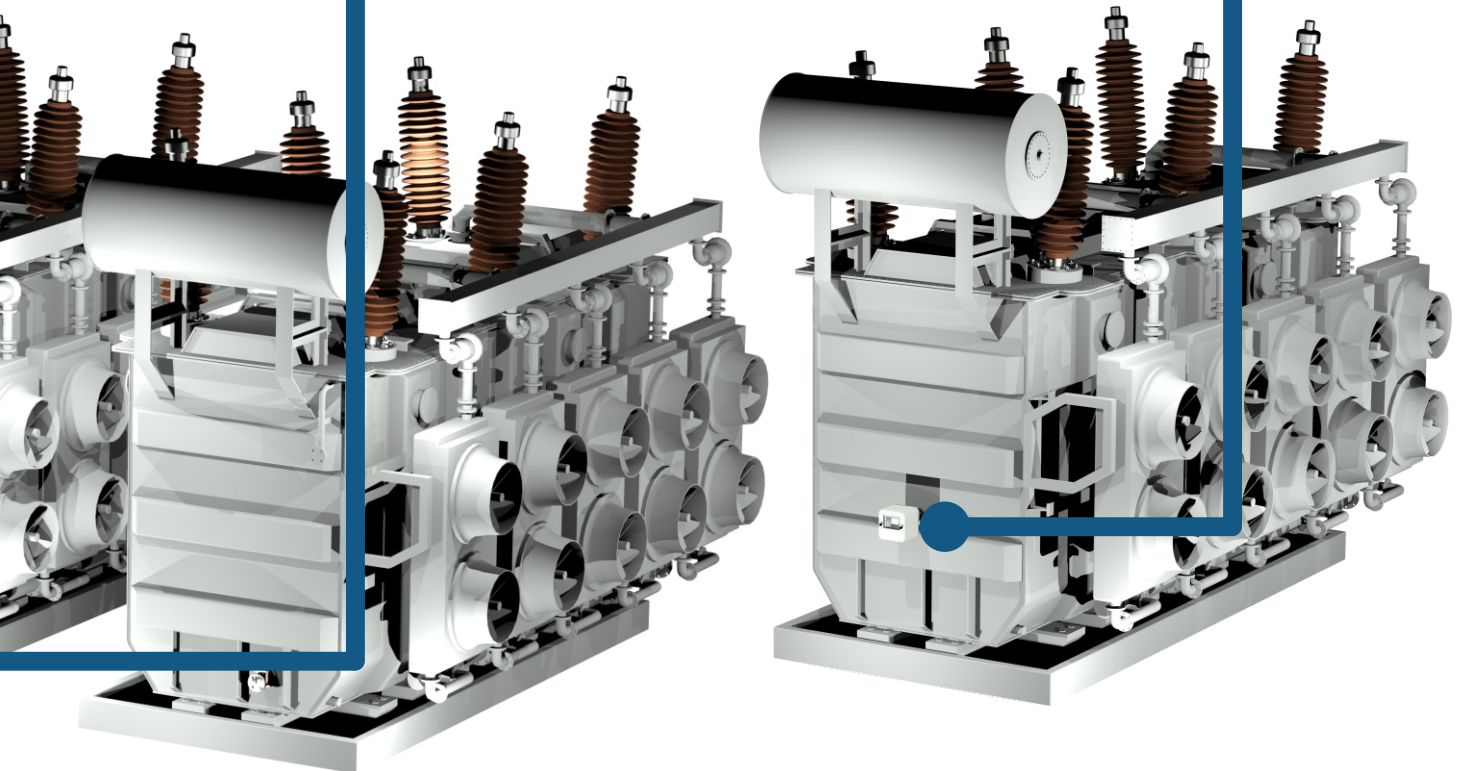

Advantages of MTE's solutions for Transformer Monitoring

- Permanent and condition based online monitoring of power transformer
- Early warning
- Less risk of expensive power outages
- Reduced on-site inspections
- Maintenance free system
- Extending transformer life time due to improved preventative maintenance and faster reaction time in case of failures
- Modular system components and extension packages for the specific customer requirements
- Easy and fast mounting on the operating power transformer
- Approved solution with more than 9'300 units supplied

The following MTE leaflets are available:

Overviews:	Company Portrait / Portable Test Equipment / Stationary Meter Test Systems Automatic Test Systems / Transformer Monitoring / E-Mobility Testing
Comparator:	K2008
Portable Reference Standards:	PRS 600.3 / CALPORT 300
Portable Working Standards:	PWS 3.3 <i>genX</i> / PWS 2.3 <i>genX</i>
Portable Standards:	CheckMeter 2.3 <i>genX</i>
Portable Test Systems:	PTS 400.3 PLUS / PTS 3.3 <i>genX</i> / PTS 2.3 <i>genX</i> CheckSystem 2.3 / CheckSystem 2.1 / CheckSystem 2.1 S
Portable Power Sources:	PPS 400.3 / PPS 3.3 <i>genX</i> / CheckSource 2.3
Software:	CALegration®

MTE Meter Test Equipment

MTE Meter Test Equipment AG

Landis + Gyr-Strasse 1
P.O. Box 7550
CH-6302 Zug, Switzerland
Phone: +41 41 508 39 39
Internet: www.mte.ch
e-mail: info@mte.ch

EMH Energie-Messtechnik GmbH

Vor dem Hassel 2
D-21438 Brackel, Germany
Phone: +49 4185 58 57 0
Fax: +49 4185 58 57 68
Internet: www.emh.eu
e-mail: info@emh.de

MTE India Private Ltd.

Commercial Unit - 118 & 119, First Floor
Plot No. 10, Aggarwal City Square, District Centre,
Mangalam Place, Rohini Sector-3, Delhi 110085, India
Phone: +91 11 40218105
E-Mail: info@mteindia.in

EMH Energie-Messtechnik (Beijing) Co. Ltd.

Section 305, Building 2, Ke-Ji-Yuan
Nr.1 Shangdi-Si-Jie, Shangdi-Information-Industry-Base
Haidian District
Beijing 100 085, P.R. China
Phone: +86 10 629 81 227
Mobile: +86 139 0 103 6875
Fax: +86 10 629 88 689
e-mail: guo@emh.com.cn

MTE Meter Test Equipment (UK) Ltd

4 Oval View
Woodley Stockport
Cheshire SK6 1JW, United Kingdom
Phone: +44 161 406 9604
Fax: +44 161 406 9605
e-mail: info@mte.uk.net

MTE Meter Test Equipment Inc.

4949 S Syracuse, Suite 550
Denver, CO - 80237, USA
Phone: +1 888 888 8888
e-mail: info@mteus.com



MTE Meter Test Equipment AG

 Landis + Gyr-Strasse 1 • P.O. Box 7550 • 6302 Zug • Switzerland
Phone +41-41 508 39 39 • Internet www.mte.ch

03.2022_R07
Subject to alterations